

# ELECTRIC HAND SANITIZER (2.5 GALLON)

Minimize cross contamination and ensure GFSI audit readiness with our electric hand sanitizer units.

## FEATURES

- ▶ Durable Stainless-steel design
- ▶ Touch-free system, wall mounted
- ▶ Electrically operated
- ▶ Larger footprint for better visibility
- ▶ Perfect for high-volume areas
- ▶ 2.5-gallon capacity - more time between refills
- ▶ Large, 5" fill port for easy refilling (no cartridges)
- ▶ At-a-glance low level indicator light
- ▶ Sanitizer level visibility from front of unit
- ▶ Automatic shut off on empty
- ▶ Lockable lid and pump compartment
- ▶ 1.5" wall mounting standoffs for easy wash down behind unit
- ▶ Same footprint as Safe Foods Chemical Innovation's Electric Anti-Fog and Electric Hand Soap dispensers to provide a familiar unit for both maintenance and employee use.

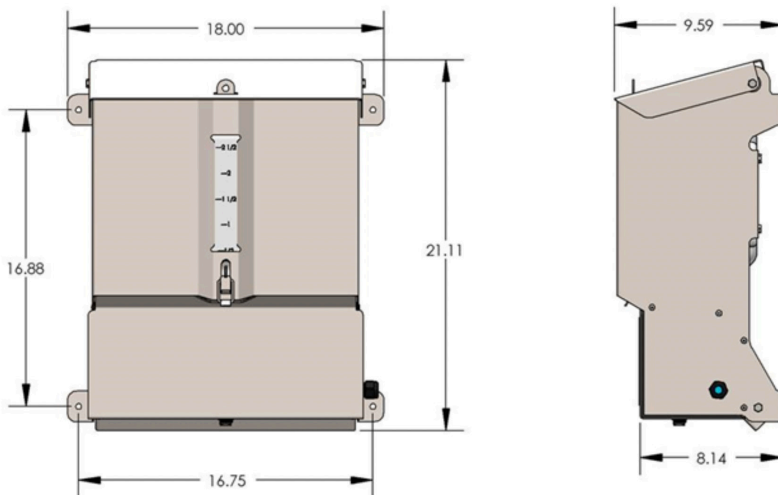

## PRODUCT ORDERING

Item #	Description
91224	Standard



ADDRESS 1501 E 8th St, North Little Rock, AR 72114

PHONE (501) 758-8500

EMAIL [SalesSFCl@pssi.com](mailto:SalesSFCl@pssi.com) WEB [www.pssi.com](http://www.pssi.com)